

Amigas and Monitors

Engineering Change Request

Document distributed August 31, 1993

Contents

WC3280 Video dongle parts - new documentation and update of existing documents

For further information, questions etc. you are welcome to contact:

<u>me</u>	<u>Responsibility</u>	<u>Email</u>	<u>cc:Mail</u>	<u>Phone</u>
Jan Nymand	Amiga Product Range	cbmehq!nymand	Jan Nymand at CBM-ESCO	+ 49 (0) 69 66 38 221
Thomas Giger	PC/OEM Products	cbmehq!giger	Thomas Giger at CBM-ESCO	+ 49 (0) 69 66 38 202
Martina Unruh	Document Requests etc.	cbmehq!unruh	Martina Unruh at CBM-ESCO	+ 49 (0) 69 66 38 175

Commodore ENGINEERING CHANGE REQUEST (SHEET 1)	ECR NO. WC 3280	DATE	SHEET
		8-12-93	1 OF 16

REASON FOR CHANGE

Documentation required for video dongle parts, both original 390682-01 and new 390682-03 sync generating version, ^{3.15} includes revisions of existing drawings and new drawings

AFFECTED PRODUCTS	TYPE OF CHANGE
AMIGAs + MONITORS	<input checked="" type="checkbox"/> REGULAR <input type="checkbox"/> EMERGENCY <input type="checkbox"/> DOC. MAINTENANCE

DRAWINGS TO BE REVISED OR DRAWN		REVISION	
DRAWING NO.	TITLE	FROM	TO (NEW)
353410	HOUSING TOP, VIDEO ADAPTOR	A	B
353411	HOUSING BOTTOM, VIDEO ADAPTOR	A	B
390682	MAIN ASS'Y, VIDEO DONGLE	New	1
365380	PCB ASS'Y, VIDEO DONGLES (SYNC + BUFFER)	New	1
365377	SCHEMATIC CCT. DWGS, VIDEO DONGLE	New	A
365378	PCB ARTWORK, VIDEO DONGLE (SYNC VERS.)	New	A
365379			
365381	FUNCTIONAL SPEC, VIDEO DONGLE (SYNC)	New	A

DESCRIPTION OF CHANGE

* Revise existing drawings 353410 and 353411 to show casework (top + bottom). Release new drawings 390682, etc., to complete required documentation.

* - changes not shown in this ECR. ECO will reflect changes

DISTRIBUTION			REVIEW AUTHORIZATION				ORIGINATOR (PRINT)	
INFO	APV	LOCATION	APP	SIGNATURE	HOLD	REJ	DATE	SHANNON DEPT. MANAGER B. BARTLON
	✓	W.C. ENG.	✓	G. Bali			8-12-93	
		W.C. SAF.						IMPLEMENTATION <input checked="" type="checkbox"/>
✓		BSW ENG.						
		BSW SAF.						<input type="checkbox"/> RUNNING CHANGE <input type="checkbox"/> NEW PRODUCTION <input type="checkbox"/> W.I.P. <input type="checkbox"/> FG. STOCK <input type="checkbox"/> IN FIELD
		HK						REMARKS
✓		PHILIPPINES						

ENGINEERING APPROVED 	REASON FOR HOLD/REJECTION				DISPOSITION OF OLD REVISION PARTS			
	SCRAP	REWORK	USE AS IS	RTV				
	D.C AUTH./PREPARED ECO				SIG: _____ DATE: _____			
	ECO #							

APPLICATION		REVISION			
NEXT ASSEMBLY	USED ON	LTR	DESCRIPTION	DATE	APPROVED
	A4000, A4000T	A	SPECIFICATION RELEASE PER ECO 930	8-3-93	SCB
	1942 monitor		ECO 3280	8/12/93	

1.0 DESCRIPTION

Two schematic circuit drawings for 23-pin to 15-pin video "dongle" adaptors are included in this document:

- 365377-01 video buffering with sync generation
(e.g., for compatibility with NEWTEK's "Video Toaster" or other gen-locking devices)
- 365377-02 simple video buffering

Commodore P/N	Status	Commodore P/N	Status
365377-01	Active		
365377-02	Active		

UNLESS OTHERWISE SPECIFIED, DIMENSIONS ARE IN MILLIMETERS. TOLERANCES: ANGLES +/- 1 DEGREE 2 PLACE DECIMALS +/- 0.5 3 PLACE DECIMALS +/- 0.25	DRAWN D. Shannon	DATE 4 JUN 93	<h1>Commodore</h1> <p>1200 WILSON DRIVE WEST CHESTER, PA. 19380 (215) 431-9100</p>	
	SYSTEM ENGR. G. Berlin	DATE		
	TEST ENGR.	DATE		
COPYRIGHT 1993 COMMODORE ELECTRONICS LTD. INFORMATION CONTAINED HEREIN IS THE UNPUBLISHED AND CONFIDENTIAL PROPERTY OF COMMODORE ELECTRONICS LIMITED. USE, REPRODUCTION, OR DISCLOSURE OF THIS INFORMATION WITHOUT THE PRIOR WRITTEN PERMISSION OF COMMODORE IS STRICTLY PROHIBITED. ALL RIGHTS RESERVED.	COMPONENTS ENGR. D. Shannon	DATE 4 JUN 93	TITLE: Schematic circuit drawings, Video "dongle" (Sync & buffer versions)	
			SIZE A	DRAWING NUMBER 365377
			SCALE	SHEET 1 of 3

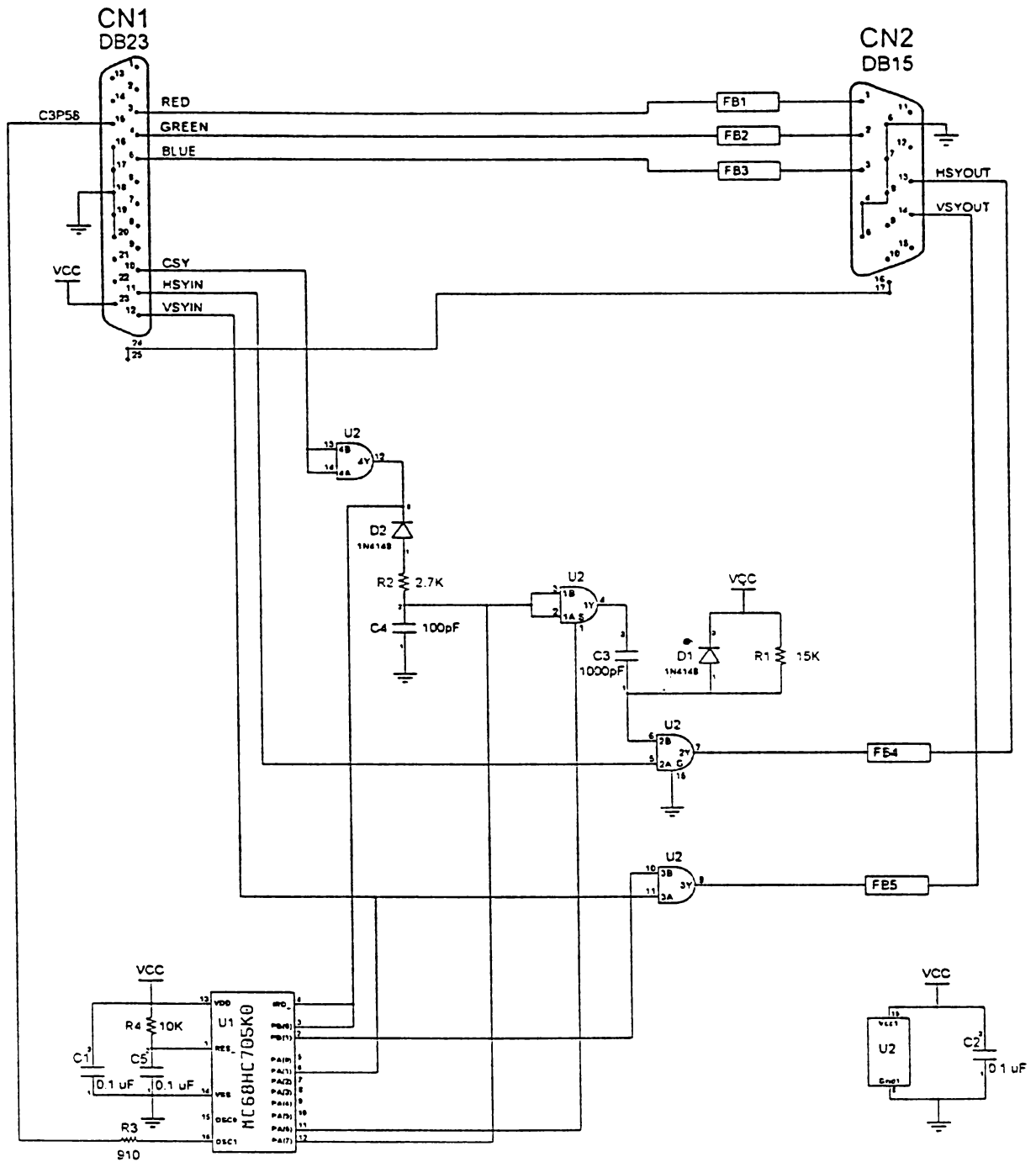

SCHMATIC CIRCUIT DRAWING 365377-01

Commodore

TITLE

Schematic circuit drawings, Video "dongle"
(Sync & buffer versions)

SIZE DRAWING NUMBER

REV

SCALE

SHEET 2 of 3

A

365377

A

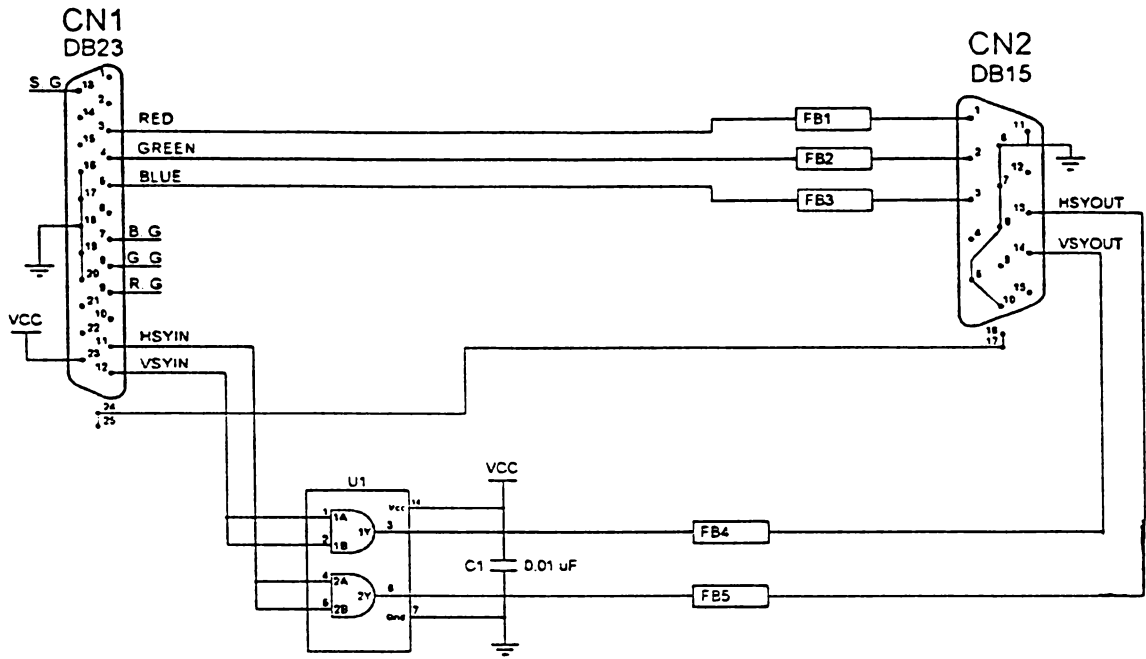

SCHEMATIC CIRCUIT DRAWING 365377-02

Commodore

TITLE

Schematic circuit drawings, Video "dongle"
(Sync & buffer versions)

SIZE

DRAWING NUMBER

REV

SCALE

SHEET 3 of 3

A

365377

A

APPLICATION		REVISION			
NEXT ASSEMBLY	USED ON	L.T.R.	DESCRIPTION	DATE	APPROVED
	A4000, A4000T	A	SPECIFICATION RELEASE PER ECO 930	8-3-93	JCB
	1942 monitor		EC 3280	9/12/93	

1.0 DESCRIPTION

Eight PCB artwork drawings for the 390682-03 23-pin to 15-pin video sync-generating "dongle" adaptor are included in this document:

COMPONENT SIDE	REV.0
SOLDER SIDE	REV.0
SILKSCREEN TOP	REV.0
SILKSCREEN BOTTOM	REV.0
DRILL LEGEND	REV.0
SOLDER MASK TOP	REV.0
SOLDER MASK BOTTOM	REV.0
SOLDER PASTE STENCIL	REV.0

Commodore P/N	Status	Commodore P/N	Status		
365378-01	Active				
UNLESS OTHERWISE SPECIFIED, DIMENSIONS ARE IN MILLIMETERS. TOLERANCES: ANGLES +/- 1 DEGREE 2 PLACE DECIMALS +/- 0.5 3 PLACE DECIMALS +/- 0.25		DRAWN D. Shannon	DATE 4JUN93	<h1 style="text-align: center;">Commodore</h1> <p style="text-align: center;">1200 WILSON DRIVE WEST CHESTER, PA. 19380 (215) 431-9100</p>	
		SYSTEM ENGR. G. Berlin	DATE		
		TEST ENGR.	DATE		
COPYRIGHT 1993 COMMODORE ELECTRONICS LTD. INFORMATION CONTAINED HEREIN IS THE UNPUBLISHED AND CONFIDENTIAL PROPERTY OF COMMODORE ELECTRONICS LIMITED. USE, REPRODUCTION, OR DISCLOSURE OF THIS INFORMATION WITHOUT THE PRIOR WRITTEN PERMISSION OF COMMODORE IS STRICTLY PROHIBITED. ALL RIGHTS RESERVED.		COMPONENTS ENGR. D. Shannon	DATE 4JUN93	TITLE: PCB ARTWORK, Video "dongle" (Sync version)	
				SIZE A	DRAWING NUMBER 365378
				SCALE	SHEET 1 of 5

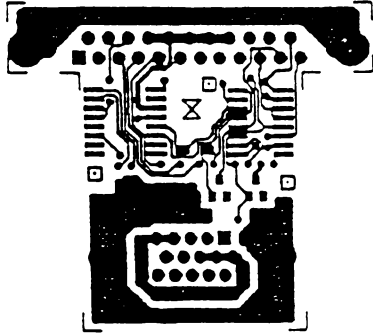

Commodore Wchest
✱ Sync Dongle Bd.
Rev 0 (5-14-93)
COMPONENT SIDE

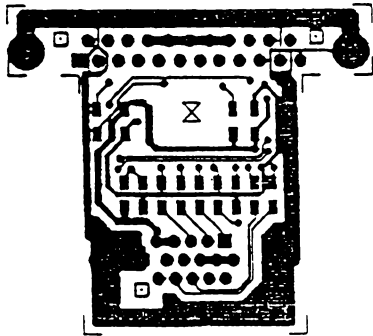

Commodore Wchest
✱ Sync Dongle Bd.
Rev 0 (5-14-93)
SOLDER SIDE

Commodore

FILE PCB ARTWORK, Video "dongle"
(Sync version)

SIZE DRAWING NUMBER

A SCALE

SHEET 2 of 5

A

365378

A

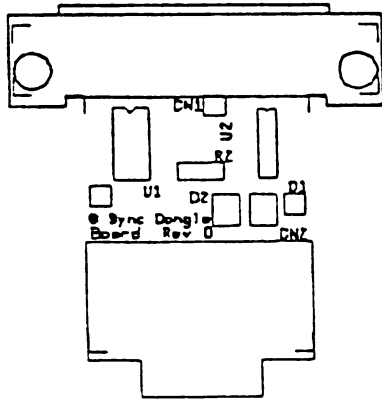

Commodore Wchest
 Ⓢ Sync Dongle Bd.
 Rev 0 (5-14-93)
 SILKSCREEN TOP

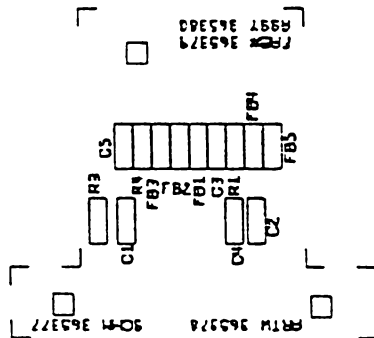

Commodore Wchest
 Ⓢ Sync Dongle Bd.
 Rev 0 (5-14-93)
 SILKSCREEN BOTTOM

Commodore

TITLE

PCB ARTWORK, Video "dongle"
 (Sync version)

SIZE

DRAWING NUMBER

REV.

SCALE

SHEET 3 of 5

A

365378

A

DIAMETER	COUNT	ALL HOLES
▷ 0.052	38	
▣ 0.125	4	
◊ 0.02	24	
▣ 0.125	1	NON PLATED

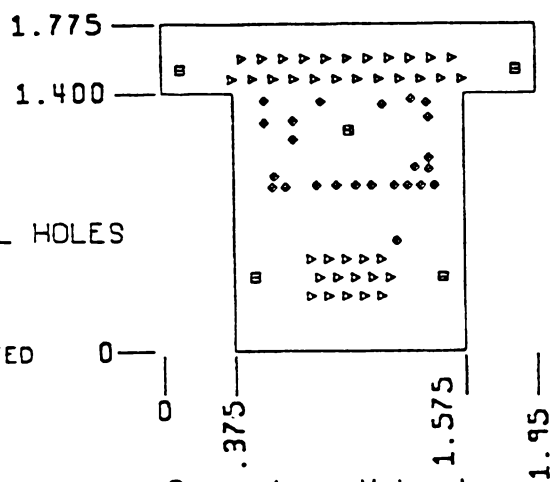

Commodore Wchest
 Sync Dongle Bd.
 Rev 0 (5-14-93)
 DRILL LEGEND

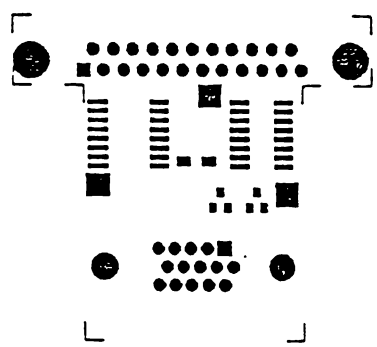

Commodore Wchest
 Sync Dongle Bd.
 Rev 0 (5-14-93)
 SOLDER MASK TOP

Commodore

TITLE: PCB ARTWORK, Video "dongle"
 (Sync version)

SIZE	DRAWING NUMBER	REV	SCALE	SHEET 4 of
A	365378	A		

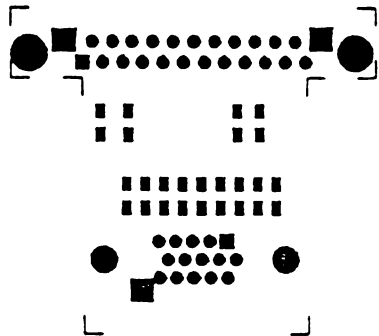

Commodore Wchest
 * Sync Dongle Bd.
 Rev 0 (5-14-93)
 SOLDER MASK BOTTOM

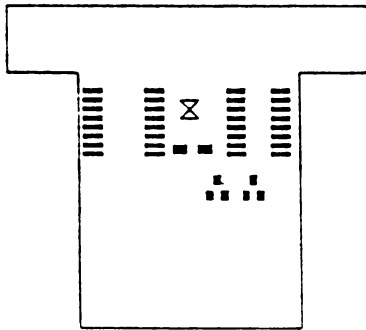

Commodore Wchest
 * Sync Dongle Bd.
 Rev 0 (5-14-93)
 SOLDER PASTE STENCIL

Commodore

TITLE

PCB ARTWORK, Video "dongle"
 (Sync version)

SIZE | DRAWING NUMBER

REV | SCALE

SHEET 5 of 5

A

365378

A

APPLICATION		REVISION			
NEXT ASSEMBLY	USED ON	LTR	DESCRIPTION	DATE	APPROVED
	A4000	A	SPECIFICATION RELEASE	6-8-93	JCB
			cc. 3280	4/11/93	

1.0 DESCRIPTION

This document describes the functional specifications for a video dongle. The video sync dongle is a device which connects the 23-pin video output on the Amiga to a standard 15-pin VGA connector. It is packaged identically to the current dongle shipped with the A4000 and high-end monitors. This new dongle provides sync processing which allows any monitor employing separate Hsync and Vsync processing to be driven from the host video output, even in the presence of a genlocking device.

2.0 BACKGROUND

Genlocking devices, genlock or Toaster, use the Hsync and Vsync lines on the Amiga to provide non-standard syncing information to the Amiga. This has the effect of rendering Hsync and Vsync useless for normal monitor operation. In order to support monitors which require separate syncs, the genlocking must provide sync separation.

The Toaster is a genlocking device which does not (and cannot) provide this service. When used entirely within a 15 KHz domain, this is not a problem. Market demands are forcing NewTek to adopt 31 KHz for their user interface screens. The solution is to provide a means for connecting the host Amiga's 23-pin video port to a 31 KHz capable monitor. This requires that the sync processing be provided to recreate Hsync and Vsync from composite sync when the system is being genlocked, and that such sync processing provide pass-through service to the syncs when the system is not being genlocked.

Commodore P/N	Status	Commodore P/N	Status			
365381-01	Active					
UNLESS OTHERWISE SPECIFIED, DIMENSIONS ARE IN INCHES (MILLIMETERS). TOLERANCES: ANGLES +/- 1 DEGREE 2 PLACE DECIMALS +/- 0.020 (0.5) 3 PLACE DECIMALS +/- 0.01 (0.25)		DRAWN joanne sugzdinis	DATE	<h1>Commodore</h1> <p>1200 WILSON DRIVE WEST CHESTER, PA. 19380 (215) 431-9100</p>		
		SYSTEM ENGR.	DATE			
		TEST ENGR.	DATE			
COPYRIGHT 1993 COMMODORE ELECTRONICS LTD. INFORMATION CONTAINED HEREIN IS THE UNPUBLISHED AND CONFIDENTIAL PROPERTY OF COMMODORE ELECTRONICS LIMITED. USE, REPRODUCTION, OR DISCLOSURE OF THIS INFORMATION WITHOUT THE PRIOR WRITTEN PERMISSION OF COMMODORE IS STRICTLY PROHIBITED. ALL RIGHTS RESERVED.		COMPONENTS ENGR. D. Shannon	DATE	TITLE: <h2>FUNCTIONAL SPECIFICATION, VIDEO SYNC DONGLE</h2>		
		CIRCUIT ENGR.	DATE			
				SIZE A	DRAWING NUMBER 365381	
				SCALE	SHEET 1 of 3	

3.0 THEORY OF OPERATION

The video sync dongle automatically selects either genlocked or normal mode of operation. The selection is based on the frequency of the vertical sync signal.

If vertical sync occurs faster than 45 Hz, then:

- (a) the machine is not being genlocked,
- (b) the horizontal frequency may be 15 KHz, 31 KHz, or other, therefore the Composite sync signal may be invalid,
- (c) the dongle selects "normal" mode, Hsync and Vsync are passed through unmolested.

If vertical sync occurs slower than 45 Hz, then:

- (a) the machine is being genlocked,
- (b) composite sync is valid,
- (c) the dongle selects "genlocked" mode, Hsync and Vsync are derived from Composite sync.

3.1 Normal Mode

The video sync dongle contains a 16-pin microprocessor U1, and a quad 2-input multiplexer U2. The microprocessor executes one of two hand-coded loops for each of the two modes. Note that the microprocessor clock is driven directly from the Amiga's 3.58 MHz output.

When the video sync dongle is in "normal" mode, the select pin U2 is driven low. This causes the Hsync and Vsync signals to be routed through the multiplexer directly to the 15-pin VGA connector. The microprocessor simply counts time between Vsyncs to determine if it should switch to "genlock" mode.

When the dongle is in "genlock" mode, operation is more complex. A major contributing factor to the complexity is that horizontal sync edges occur on both edges of the primary 3.58 MHz clock. The microprocessor, executing cycles 1.79 MHz, is incapable of driving the Hsync line directly. Therefore, some other signal processing means must be provided to generate a "correct" horizontal sync. The particular implementation of sync separation employed here is not ideal in the sense of being a straightforward design. It does have the advantages of being both inexpensive and physically small.

3.2 Genlocked Mode

In "genlock" mode, the select pin to the multiplexer is driven high, and the microprocessor executes a loop once per horizontal line synchronous with the video beam. The vertical sync output is created by simply copying the composite sync input to the vertical sync output at two places in the loop on each line. The two places in the loop are separated in time by about 1/2 of a line time. The reason for using two places instead of one is to facilitate proper operation in interlaced modes.

The Hsync output is routed from U2 in Pin 6. The circuit between U2 Pin 4 and U2 Pin 6 forms an edge detector. The time constant of C3 and R1 is selected so that the pulse length will be about the right size for a 15 KHz sync pulse. The goal of preceding circuitry is to make a low-going edge when we want Hsync output pulse to appear. U2 pins 2 and 3 can be forced to a specific state by the microprocessor. This provides a

Commodore

TITLE

FUNCTIONAL SPECIFICATION,
VIDEO SYNC DONGLE

SIZE

DRAWING NUMBER

REV

SCALE

SHEET 2 OF 3

A

365381

A

means for the microprocessor to block the passage of serration pulses in the composite sync from pass through to the Hsync output, and also provides a means for the microprocessor to stretch the size of a short Hsync pulse (seen during vertical blanking) to sufficient length to allow C1 and R3 to operate.

During each horizontal line, the microprocessor drives U2 pins 2 and 3 high, and waits for Csync to be high. The microprocessor then releases U2 pins 2 and 3. When Csync falls, the edge is passed to the edge detector, and the microprocessor immediately drives U2 pins 2 and 3 low in order to stretch serration pulses. The microprocessor then waits approximately 1/4 of a line, samples Csync for Vsync, waits 1/2 line, samples Csync for Vsync again, and returns to the top of the loop waiting for Csync to be high.

The rationale behind the requirement of D1 is that the microprocessor cannot execute the code between the release of U2 pins 2 and 3 and the driving of U2 pins 2 and 3 low quickly enough. When composite sync falls, C4 is discharged quickly but is not recharged when Csync rises again. This allows the microprocessor time to clamp U2 pins 2 and 3 low.

Within the horizontal loop described above, code to count the number of lines between vertical syncs and for branching out of the loop is initiated. This code is all in one place, but is spread out so as to allow the real-time operations of vertical sampling to execute properly.

Commodore

TITLE

FUNCTIONAL SPECIFICATION,
VIDEO SYNC DONGLE

SIZE DRAWING NUMBER

REV SCALE

SHEET 3 OF

A

365381

A



This was brought to you

from the archives of

<http://retro-commadore.eu>