

Parts List  
for  
Power Supply for AMIGA " European Version "

(Shindengen Model Name : CA1000PS/EC)

Symbol on Schematic	Name	Model Name	Q'ty	Remarks
F40	Fuse	EAK3.15A-T or S506	1	EAK3.15A-T : 3.15 Amps, DIN 41662
	Fuse Clip	85PN0819	2	
THY40	Thyristor	5P6M	1	Olvis Co.
RF40	Bridge Diode	S4VB60	1	
Q40	Transistor	2SC3376	1	S506 : 3.15 Amps, IEC127
	do.	or 2SC2792		
Q41	do.	2SC1173	1	Kenneth Beswick Ltd.
D40	Silicon Diode	EU2Z or V19C	1	
D41	do.	1S2075K	1	
D46	do.	DFG1A8	1	
D51, D52	do.	1S2075K	2	
D60	do.	V06E	1	
DZ41	Zener Diode	HZ16-1	1	
DZ42	do.	HZ5A-3	1	
DZ60-64	do.	HZ20-2L	5	
PC01	Opto-Coupler	TLP581	1	PC01, and PC02. VDE Certificate
PC02	do.	do.	1	
T40	Transformer	60 VA	1	No.37411
L40, L41	Chiking Coil	SF-T10-50-02	2	Toshiba Co., Ltd.
L42, L43	do.	EL-18D602	1	
C40, C41	Capacitor	DE7090B102KVA1	2	C40, C41, and C47. VDE Certificate
C47	do.	DE7100FZ472PVA1	1	
C80	do.	DE0910R221K	1	19764/19765/19766 35029/35030.
C42	do.	ECQ-E2A 474MW	1	
C43	do.	ECQ-E2A 103MW	1	Murata Co., Ltd.
C45	do.	TDY1H/2A	1	
C46	do.	TDXM2J 473KD	1	C42 and C43. VDE File No.
C51, C53	do.	TDY1H/2A 683K	2	
C52	do.	TDY1H/2A 333	1	4811.6-4670-1035/A1 Panasonic Co., Ltd.
C54	do.	TDY1H/2A 104K	1	
C55	do.	TDY1H/2A 222K	1	
C49	do.	CEUSM 1V 100	1	
C50	do.	LHS2G181MHSABV	1	
R42	Resistor	MPC70 0.47Ω	1	
R43	do.	L53K100JF 5W 10Ω	1	
R49	do.	MNS05N 390KΩ	1	
R39, R40	do.	RSX1 or RSF1BL 82KΩ	2	
R46, R47	do.	RSX1 or RSF1BL 82KΩ	2	
R80	do.	RSX1 or RSF1BL 82Ω	1	
R61	do.	RSX2 or RSF2BL 33KΩ	1	
R62	do.	RSX1 or RSF1BL 100KΩ	1	
R41	do.	1/4 W 10KΩ	1	
R44	do.	1/4 W 680Ω	1	
R45	do.	1/4 W 68Ω	1	
R50	do.	1/4 W 820Ω	1	
R51	do.	1/4 W 220Ω	1	
R52	do.	1/4 W 330Ω	1	
R53, R56	do.	1/4 W 15Ω	2	
R54	do.	1/4 W 1.5KΩ	1	
R55	do.	1/4 W 820Ω	1	

Parts List  
for  
Power Supply for AMIGA " European Version "

(Shindengen Model Name : CA1000PS/EC)

Symbol on Schematic	Name	Model Name	Q'ty	Remarks
R60	Resistor	1/4 W 560K $\Omega$	1	
D01	Silicon Diode	S30C4M	1	
D02	do.	5CH2M or ESAC25-02	1	
D03	do.	EU2A or 1S2675	1	
IC01	Integrates cct.	1R9431	1	
IC02	do.	SI-3122V	1	
IC03	do.	$\mu$ PC-7805A	1	
IC04	do.	HD74LS14P or SN74LS14P	1	
L01	Choking Coil	RD1113A 3J	1	
C09	Capacitor	CEUSM 1H 4R7	1	
C10	do.	CEUSM 1H 010	1	
C15	do.	CEUSM 101	1	
C17,C19	do.	CEUSM 101	2	
C11-C13	do.	SXA 10VB 2200 F	3	
C16	do.	SXA 35VB 470 F	1	
C18	do.	SXA 25VB 330 F	1	
C22	do.	THY1H/2A	1	
C21	do.	ECK F1H 221KB	1	
R14	Resistor	RSX2 or RSF2BL 33	1	
R10	do.	1/4 W 68	1	
R11	do.	1/4 W 560	1	
R12	do.	1/4 W 390	1	
R15	do.	1/4 W 470	1	
R17	do.	1/4 W 5.6K	1	
R21	do.	1/4 W 1K	1	
R22	do.	1/4 W. 220	1	
RV01,02	Variable R.	EVM38GA 00B 52	2	
FAN	Fan Motor	126LH2181 023	1	FAN : VDE Approval
CN01	AC Inlet	Type 0307	1	No.1717
SW1	AC Switch	EST-15	1	Etri Co.,Ltd.
				AC Inlet : VDE File No. 9412-1550-1003/A3K Hori Electric Co., Ltd.
				AC Switch : VDE File No. 4811.6-1-4401-1013/A8K Panasonic Co., Ltd.

Parts List  
for  
Power Supply for AMIGA " European Version "



(Shindengen Model Name : CA1000PS/EC)

Symbol on Schematic	Name	Model Name	Q'ty	Remarks
<u>F40</u>	Fuse	EAK3.15A-T or S506	1	EAK3.15A-T : 3.15 Amps, DIN 41662 Olvis Co.
	Fuse Clip	85PN0829	2	
THY40	Thyristor	5P6M	1	
RF40	Bridge Diode	S4VB60	1	
Q40	Transistor	2SC3376	1	S506 : 3.15 Amps, IEC127 Kenneth Beswick Ltd.
	do.	or 2SC2792		
Q41	do.	2SC1173	1	
D40	Silicon Diode	EU2Z or V19C	1	
D41	do.	1S2075K	1	
D46	do.	DFG1A8	1	
D51, D52	do.	1S2075K	2	
D60	do.	V06E	1	
DZ41	Zener Diode	HZ16-1	1	
DZ42	do.	HZ5A-3	1	
DZ60-64	do.	HZ20-2L	5	
<u>PC01</u>	Opto-Coupler	TLP581 or TLP580	1	PC01, and PC02.
<u>PC02</u>	do.	TLP581	1	VDE Certificate
T40	Transformer	60 VA	1	No.37411
L40, L41	Chiking Coil	SF-T10-50-02	2	Toshiba Co., Ltd.
<u>L42, L43</u>	do.	EL-18D417	1	
C40, C41	Capacitor	DE7090B102KVA1	2	C40, C41, and C47. VDE Certificate
<u>C47</u>	do.	DE7150F472MVA1	1	
C80	do.	DE0910R221K	1	19764/19765/19766
C42	do.	ECQ-E2A 474MW	1	35029/35030. Murata Co., Ltd.
C43	do.	ECQ-E2A 103MW	1	
C45	do.	TDY1H/2A	1	
C46	do.	TDXM2J 473KD	1	C42 and C43.
C51, C53	do.	TDY1H/2A 683K	2	VDE File No.
C52	do.	TDY1H/2A 333	1	4811.6-4670-1035/A2
C54	do.	TDY1H/2A 104K	1	Panasonic Co., Ltd.
C55	do.	TDY1H/2A 222K	1	
C49	do.	CEUSM 1V 100	1	
<u>C50</u>	do.	LHS2G181MHSABV	1	or ECES29U180S
R42	Resistor	MPC70 0.47Ω	1	
R43	do.	L53K100JF 5W 10Ω	1	
R49	do.	MNS05N 390KΩ	1	
R39, R40	do.	RSX1 or RSF1BL 82KΩ	2	
R46, R47	do.	RSX1 or RSF1BL 82KΩ	2	
R80	do.	RSX1 or RSF1BL 82Ω	1	
<u>R61</u>	do.	RSX2 or RSF2BL 22KΩ	1	
<u>R62</u>	do.	RSX1 or RSF1BL 100KΩ	1	
R41	do.	1/4 W 10KΩ	1	
R44	do.	1/4 W 680Ω	1	
R45	do.	1/4 W 68Ω	1	
R50	do.	1/4 W 820Ω	1	
R51	do.	1/4 W 220Ω	1	
R52	do.	1/4 W 330Ω	1	
R53, R56	do.	1/4 W 15Ω	2	
R54	do.	1/4 W 1.5KΩ	1	
R55	do.	1/4 W 820Ω	1	

Parts List  
for  
Power Supply for AMIGA " European Version "



(Shindengen Model Name : CA1000PS/EC)

Symbol on Schematic	Name	Model Name	Q'ty	Remarks
<u>R60</u>	Resistor	<u>None</u>		
D01	Silicon Diode	S30C4M	1	
D02	do.	5CH2M or ESAC25-02	1	
D03	do.	EU2A or 1S2675	1	
IC01	Integrates cct.	1R9431	1	
IC02	do.	SI-3122V	1	
IC03	do.	μPC-7805A	1	
IC04	do.	HD74LS14P or SN74LS14P	1	
L01	Choking Coil	RD1113A 3J	1	
C09	Capacitor	CEUSM 1H 4R7	1	
C10	do.	CEUSM 1H 010	1	
C15	do.	CEUSM 101	1	
C17,C19	do.	CEUSM 101	2	
C11-C13	do.	SXA 10VB 2200 F	3	
C16	do.	SXA 35VB 470 F	1	
C18	do.	SXA 25VB 330 F	1	
C22	do.	THY1H/2A	1	
C21	do.	ECK F1H 221KB	1	
R14	Resistor	RSX2 or RSF2BL 33Ω	1	
R10	do.	1/4 W 68Ω	1	
R11	do.	1/4 W 560Ω	1	
R12	do.	1/4 W 390Ω	1	
R15	do.	1/4 W 470Ω	1	
R17	do.	1/4 W 5.6KΩ	1	
R21	do.	1/4 W 1KΩ	1	
R22	do.	1/4 W 220Ω	1	
RV01,02	Variable R.	EVM38GA 00B.52Ω	2	
FAN	Fan Motor	126LH2181 023	1	FAN : VDE Approval
<u>N01</u>	AC Inlet	Type <u>0370</u>	1	No.1717
<u>JW1</u>	AC-Switch	EST-15	1	Etri Co.,Ltd.
				AC Inlet : VDE File No. 9412-1550-1003/A3K
				AC Switch : VDE File No. 4811.6-1-4401-1013/A8K



*Shindengen Electric Manufacturing Co., Ltd.*

NEW-OHEMACHI BLDG.      2-1, 2-CHOME OHEMACHI,      CHIYODA-KU, TOKYO 100 JAPAN  
TELEPHONE: (03) 279-4431      TELEFAX: (03) 279-6478 GIII      TELEX: 222-2539 DENGEN J  
Cables: "SHINDENGEN TOKYO"

December 03, 1985

Specification of Power Supply for AMIGA " European Version "

(Shindengen Model Name      CA1000PS/EC)

1. Scope

This specification defines the power supply to be used in the AMIGA personal computer " European Version ".

2. General

55 Watts power output.  
Metal enclosure type.  
Cooling fan built-in.  
Designed to meet IEC 380 class 1, and FTZ class B.

3. Electrical Requirement

\*\* Input

198 - 264 VAC ( 220 VAC  $\pm$  10 %, 240 VAC  $\pm$  10% )  
50 Hz  $\pm$  10 %  
Input current surge limited to 32 amperes (0-Peak, 240VAC)

\*\* Output

Voltage	Current		Stability	Ripple & Noise
	Min.	Max.		
+ 5VDC	2.0	8.0 A	$\pm$ 5 %	150 mV P-P
+ 12VDC	0	1.0 A	$\pm$ 5 %	150 mV P-P
- 5VDC	0	0.25 A	$\pm$ 5 %	150 mV P-P
Hold-Up Time	More than 20 mS ( At 240VAC, Max. Load )			
Turn on delay	100 mS (Typical)			
Start up time	500 mS or less			

\*\* Short Circuit Protection

Short circuit protection has been adjusted the following current limit range.

+ 5 VDC output : 8.2 - 11.0 A  
+ 12 VDC output : 1.2 - 2.0 A  
- 5 VDC output : 0.3 - 2.5 A

**\*\* Withstand Voltage**

3,750 VAC

Between primary circuit and secondary circuit.

1,250 VAC for 1 minute.

Between primary circuit and ground.

At 25°C, R.H. 65 %, Set current for shut off is 30mA.  
Eliminate capacitors inserted between primary and ground,  
between secondary and ground at testing.

**\*\* Isolation**

More than 50 MΩ at 500 Vdc.

Between primary circuit and secondary circuit.

Between primary circuit and ground.

At 25°C, R.H. 65 %.

**\*\* Leakage Current**

0.75 mA or less.

At 240 VAC, Maximum load, Conformed to IEC.

4. Efficiency

More than 65 %

At 240 VAC, Maximum load.

5. 50 Hz " Tick " signal

at TTL drive 1 TTL load

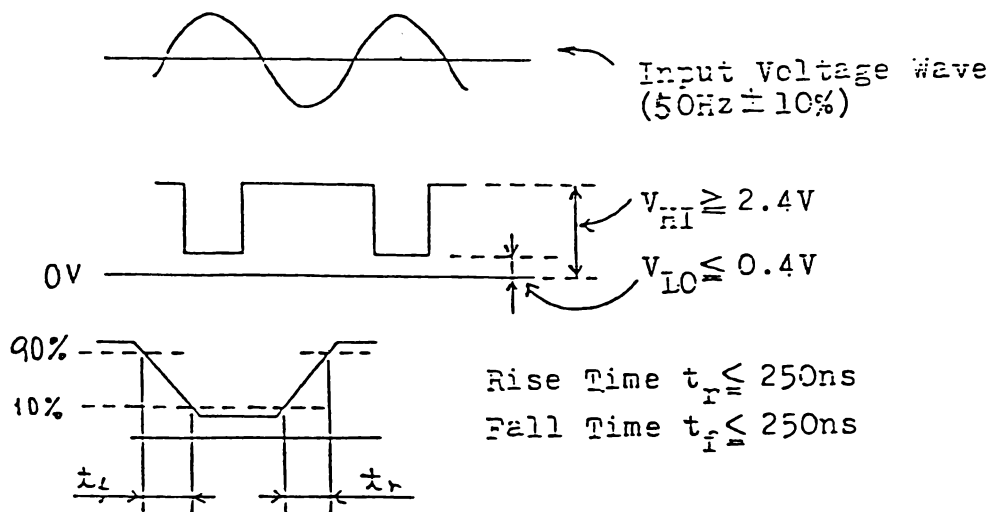

6. Enviromental Ranges

** Temperature			
Operating	0°C	-	60°C
Storage	-20°C	-	75°C
** Relative Humidity			
Operating	30 %	-	85 %
Storage	30 %	-	85 %

Note. Non-condensing.

**\*\* Vibration**

10 - 55 Hz of 2G for one hour in each of three orthagonal axes.

**\*\* Shock**

Three impacts of 20G in each of three orthagonal axes.

7. Applicable Safety Standard

Designed to meet IEC 380 class 1.

8. Applicable Noise Standard

Designed to meet FTZ class B.

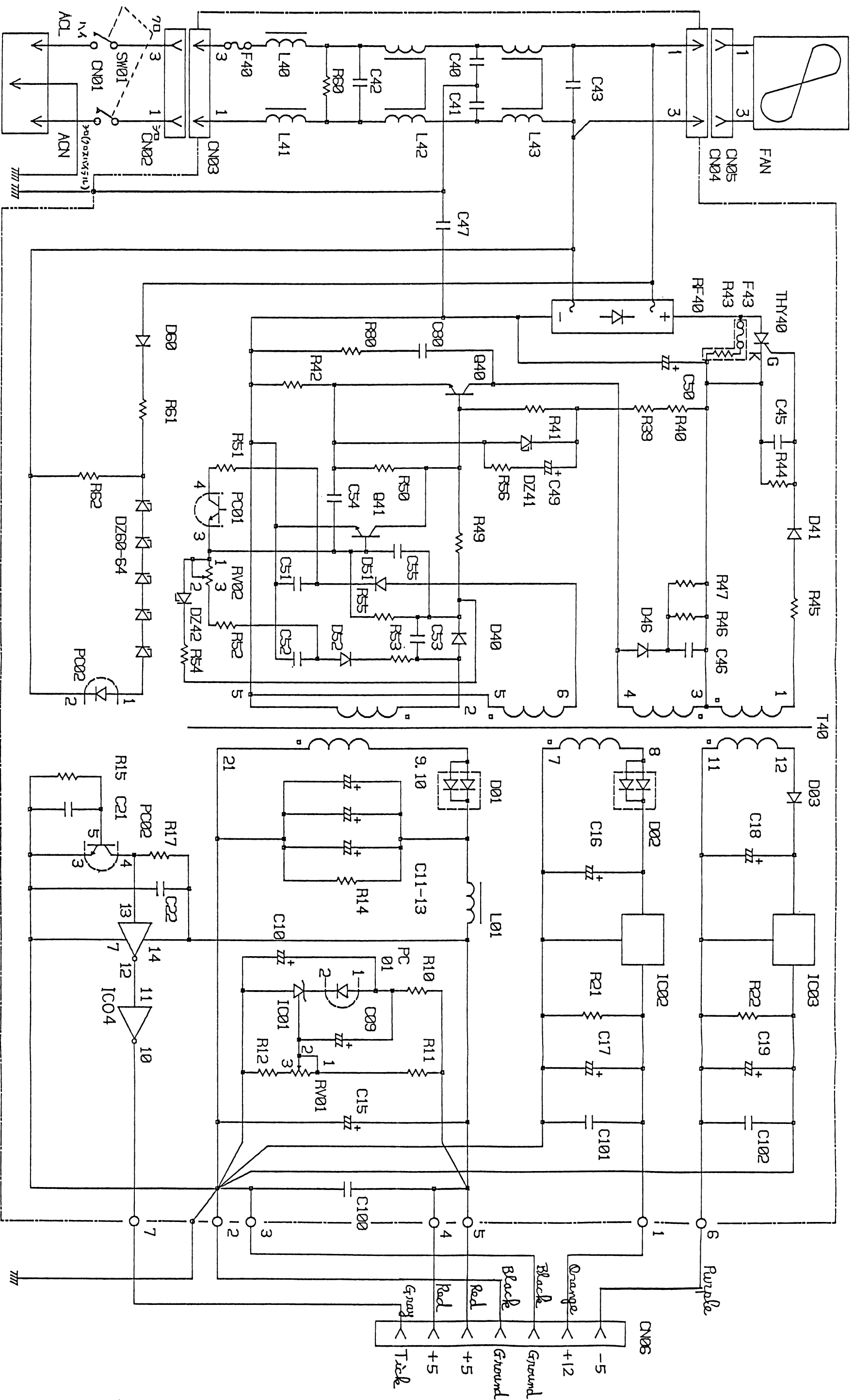

MATL.	材料
TRMT.	処理

EDIT 版	DATE 年月日	DECD. 設計	DESCRIPTION 記	UNIT 単位	SCALE 尺度	3RD ANGLE PROJ. 第三角法
1	3.85			mm		
SHINDENGEN ELECTRIC MFG. CO., LTD.						
新電元工業株式会社 JAPAN						
APPD. 承認	Y. Noto	CHKD. 検図	S. Sekiguchi	TITLE 名称 POWER SUPPLY FOR AMIGA		
CA1000PS/EC				DWG. NO. 番 WM-858260		
SHEET 1/1				EDT. 版		



**This was brought to you**

**from the archives of**

**<http://retro-commadore.eu>**